

# SN65220, SN65240, SN75240 SINGLE AND DUAL UNIVERSAL SERIAL BUS PORT TRANSIENT SUPPRESSORS

SLLS266D – FEBRUARY 1997 – REVISED OCTOBER 2000

- Design to Protect Submicron 3-V or 5-V Silicon from Noise Transients
- Applicable to Two High- or Low-Speed Universal Serial Bus (USB) Host, Hub, or Peripheral Ports
- Port ESD Protection Capability Exceeds:
  - 15-kV Human Body Model
  - 2-kV Machine Model
- Low Current Leakage . . . 1  $\mu$ A Max
- Stand-Off Voltage . . . 6.0 V Min
- Low Capacitance . . . 35 pF Typ

## description

The SN65220 is a single transient voltage suppressor and the SN75240 and SN65240 are dual transient voltage suppressors designed to provide additional electrical noise transient protection to two USB ports. Any cabled I/O can be subjected to electrical noise transients from various sources. These noise transients can cause damage to the USB transceiver and/or the USB ASIC if they are of sufficient magnitude and duration. The USB ports are typically implemented in 3-V or 5-V digital CMOS with very limited ESD protection. The SN65220, SN75240, and SN65240 can significantly increase the port ESD protection level and reduce the risk of damage to the large and expensive circuits of the USB port.

The SN75240 is characterized for operation from 0°C to 70°C. The SN65220 and SN65240 are characterized for operation from -40°C to 85°C. IEC1000-4-2 ESD performance is measured at the system level and system design influences the results of these tests. A high compliance level may be attained with proper system design.

IEC1000-4-2 Compliance Test Levels

IEC1000-4-2 COMPLIANCE LEVEL	MAXIMUM TEST VOLTAGE	
	CONTACT DISCHARGE (kV)	AIR DISCHARGE (kV)
1	2	2
2	4	4
3	6	8
4	8	15

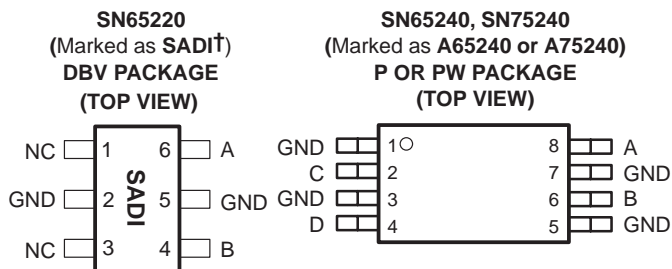

NC – No internal connection  
†When read horizontally, Pin 1 is the bottom left pin.

## schematic

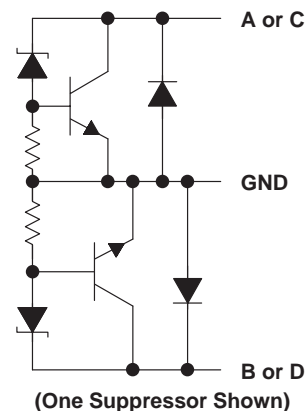

NOTE A: All four GND terminals should be connected to ground.

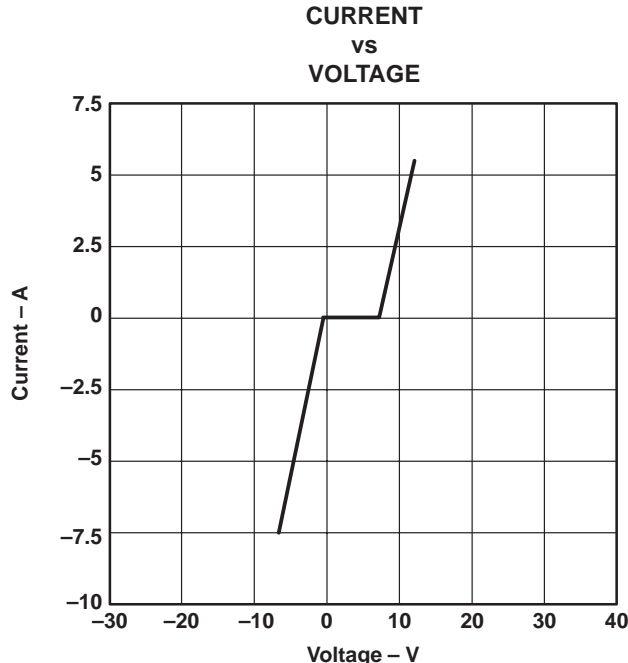

NOTE A: Typical current versus voltage curve was derived using the IEC 1.2/50- $\mu$ s surge waveform.



Please be aware that an important notice concerning availability, standard warranty, and use in critical applications of Texas Instruments semiconductor products and disclaimers thereto appears at the end of this data sheet.

PRODUCTION DATA information is current as of publication date. Products conform to specifications per the terms of Texas Instruments standard warranty. Production processing does not necessarily include testing of all parameters.

**TEXAS  
INSTRUMENTS**

POST OFFICE BOX 655303 • DALLAS, TEXAS 75265

Copyright © 2000, Texas Instruments Incorporated

# SN65220, SN65240, SN75240 SINGLE AND DUAL UNIVERSAL SERIAL BUS PORT TRANSIENT SUPPRESSORS

SLLS266D – FEBRUARY 1997 – REVISED OCTOBER 2000

## absolute maximum ratings over operating free-air temperature range (unless otherwise noted)†

Continuous total power dissipation	See Dissipation Rating Table
Electrostatic discharge	Class 3, A:15 kV, B: 2 kV
Peak power dissipation, $P_{D(peak)}$	60 W
Peak forward surge current, $I_{FSM}$	3 A
Peak reverse surge current, $I_{RSM}$	-9 A
Storage temperature range, $T_{stg}$	-65°C to 150°C
Lead temperature 1,6 mm (1/16 inch) from case for 10 seconds	260°C

† Stresses beyond those listed under “absolute maximum ratings” may cause permanent damage to the device. These are stress ratings only, and functional operation of the device at these or any other conditions beyond those indicated under “recommended operating conditions” is not implied. Exposure to absolute-maximum-rated conditions for extended periods may affect device reliability.

DISSIPATION RATING TABLE

PACKAGE	$T_A \leq 25^\circ\text{C}$ POWER RATING	DERATING FACTOR ABOVE $T_A = 25^\circ\text{C}$	$T_A = 70^\circ\text{C}$ POWER RATING	$T_A = 85^\circ\text{C}$ POWER RATING
DBV	385 mW	3.1 mW/°C	246 mW	200 mW
P	1150 mW	9.2 mW/°C	736 mW	598 mW
PW	520 mW	4.2 mW/°C	331 mW	268 mW

‡ This is the inverse of the junction-to-ambient thermal resistance when board-mounted and with no air flow.

## recommended operating conditions

		MIN	MAX	UNIT	
		Operating free-air temperature, $T_A$	SN65240, SN65220		-40
		SN75240	0	70	

## electrical characteristics over recommended operating conditions (unless otherwise noted)

PARAMETER	TEST CONDITIONS	MIN	TYP	MAX	UNIT
$I_{lkg}$ Leakage current	$V_I = 6\text{ V}$ at A, B, C, or D terminals			1	$\mu\text{A}$
$V_{(BR)}$ Breakdown voltage	$V_I = 1\text{ mA}$ at A, B, C, or D terminals	6.5	7	8	V

## APPLICATION INFORMATION

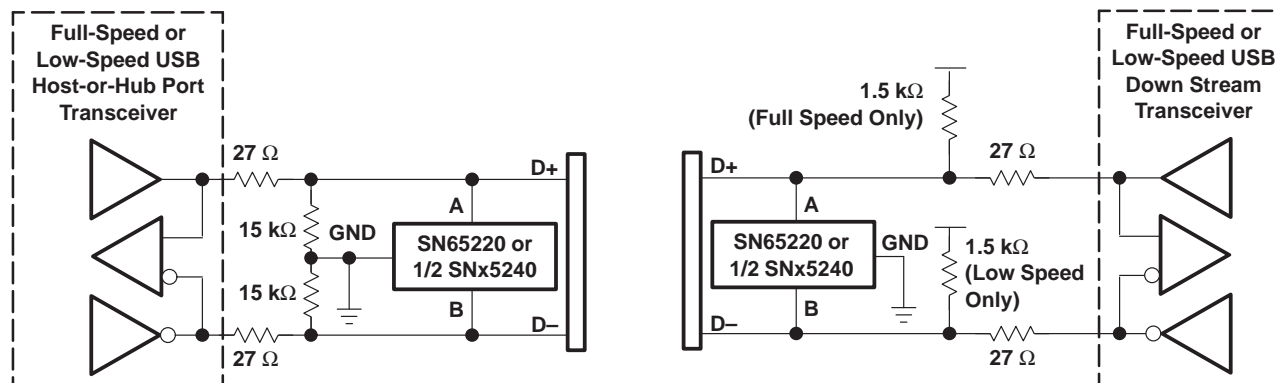

Figure 1. Typical USB Application

SN65220, SN65240, SN75240  
 SINGLE AND DUAL UNIVERSAL SERIAL BUS PORT  
 TRANSIENT SUPPRESSORS

SLLS266D – FEBRUARY 1997 – REVISED OCTOBER 2000

MECHANICAL INFORMATION

DBV (R-PDSO-G6)

PLASTIC SMALL-OUTLINE

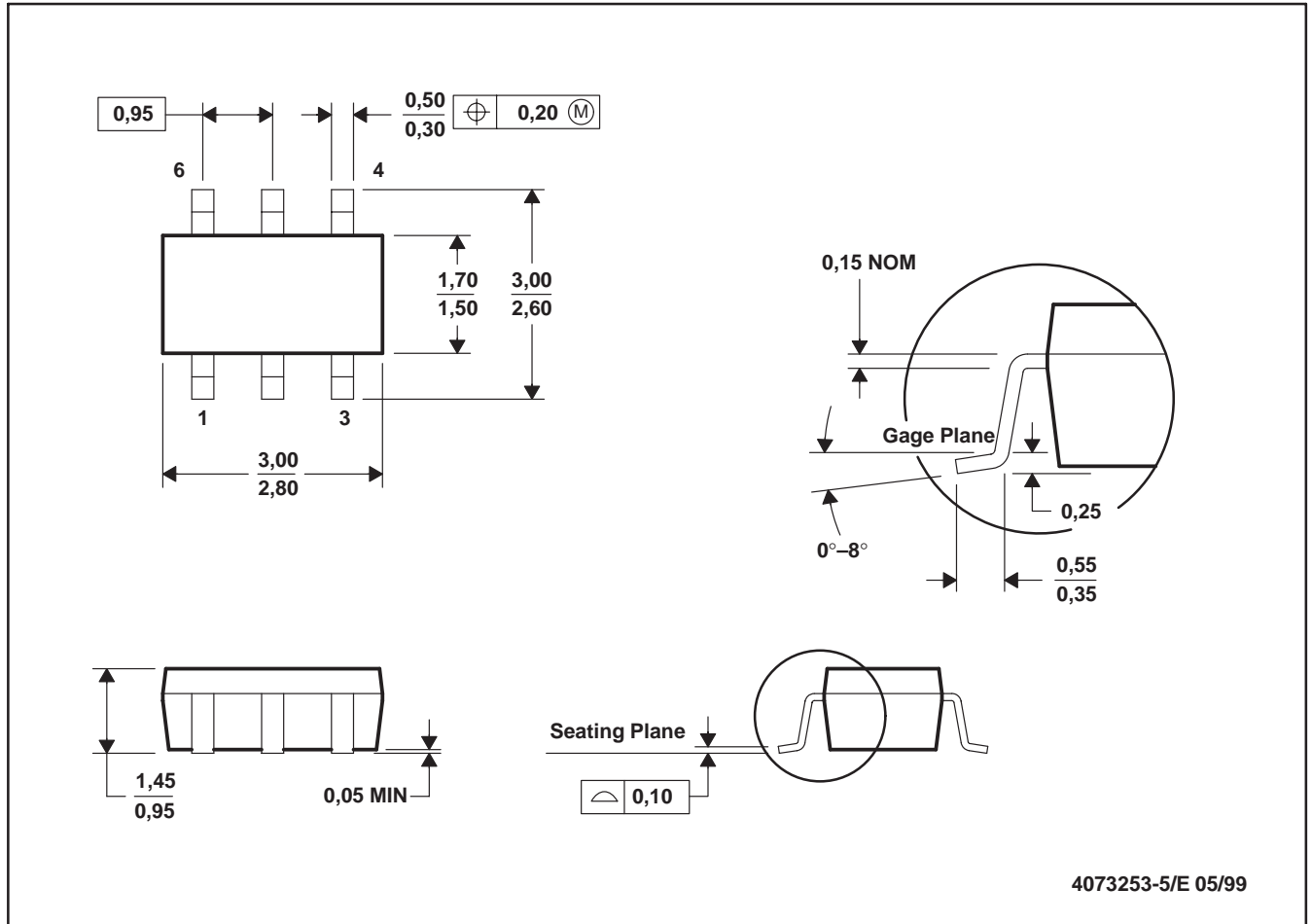

4073253-5/E 05/99

- NOTES: A. All linear dimensions are in millimeters.  
 B. This drawing is subject to change without notice.  
 C. Body dimensions do not include mold flash or protrusion.

**SN65220, SN65240, SN75240**  
**SINGLE AND DUAL UNIVERSAL SERIAL BUS PORT**  
**TRANSIENT SUPPRESSORS**

SLLS266D – FEBRUARY 1997 – REVISED OCTOBER 2000

**MECHANICAL INFORMATION**

**P (R-PDIP-T8)**

**PLASTIC DUAL-IN-LINE PACKAGE**

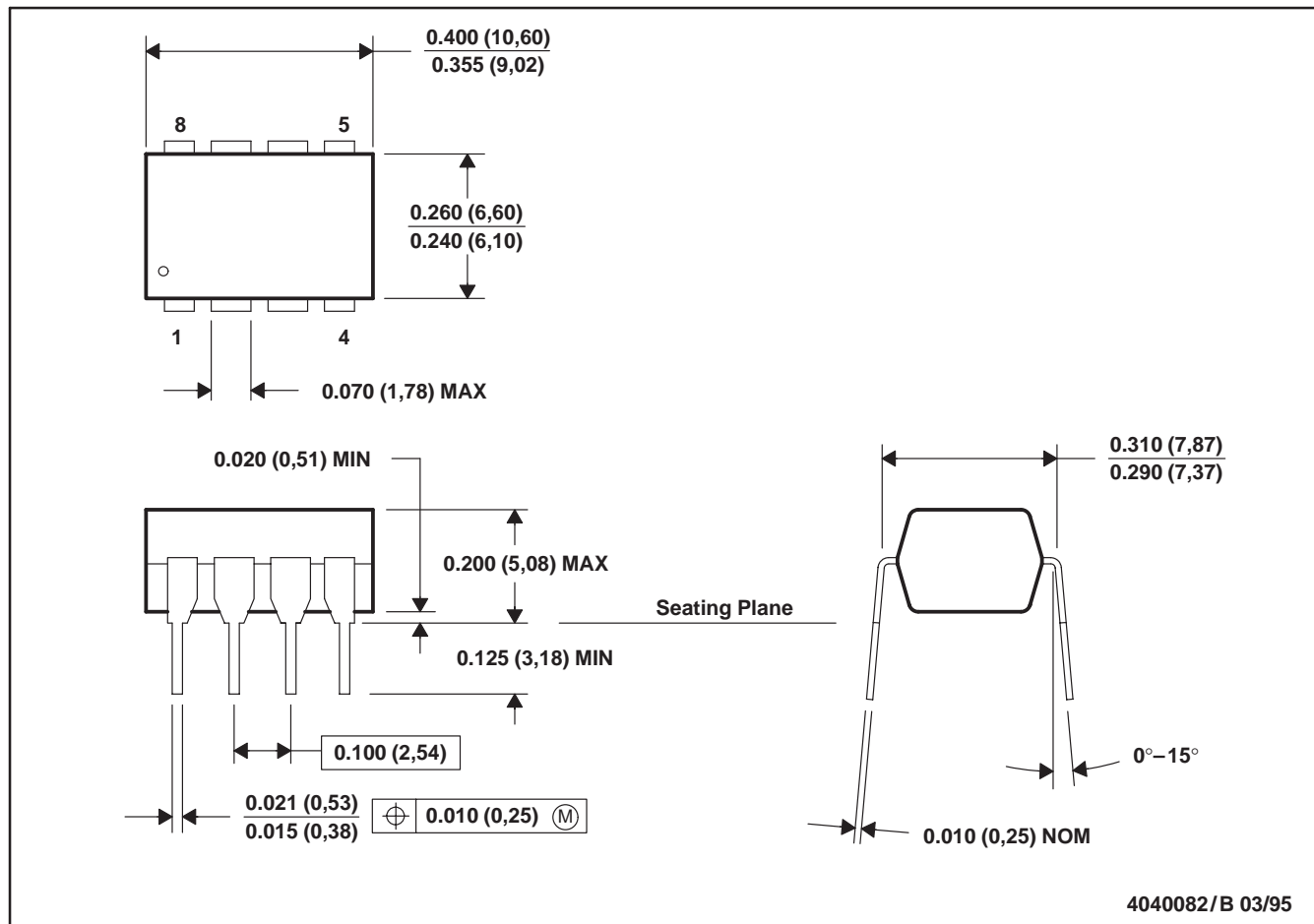

- NOTES: A. All linear dimensions are in inches (millimeters).  
 B. This drawing is subject to change without notice.  
 C. Falls within JEDEC MS-001

SN65220, SN65240, SN75240  
 SINGLE AND DUAL UNIVERSAL SERIAL BUS PORT  
 TRANSIENT SUPPRESSORS

SLLS266D – FEBRUARY 1997 – REVISED OCTOBER 2000

MECHANICAL INFORMATION

PW (R-PDSO-G\*\*)

PLASTIC SMALL-OUTLINE PACKAGE

14 PIN SHOWN

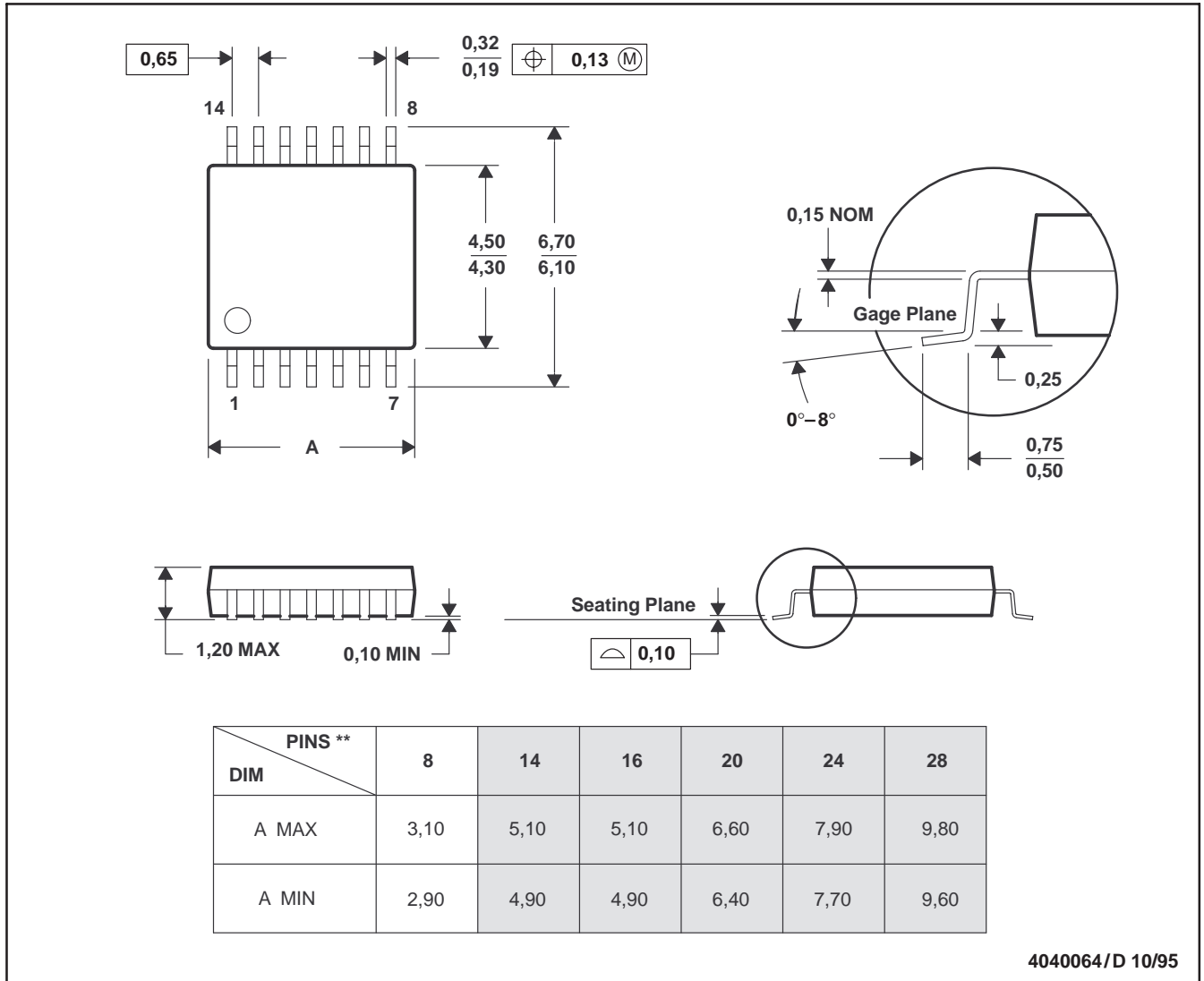

4040064/D 10/95

- NOTES: A. All linear dimensions are in millimeters.  
 B. This drawing is subject to change without notice.  
 C. Body dimensions do not include mold flash or protrusion not to exceed 0,15.  
 D. Falls within JEDEC MO-153

## IMPORTANT NOTICE

Texas Instruments and its subsidiaries (TI) reserve the right to make changes to their products or to discontinue any product or service without notice, and advise customers to obtain the latest version of relevant information to verify, before placing orders, that information being relied on is current and complete. All products are sold subject to the terms and conditions of sale supplied at the time of order acknowledgment, including those pertaining to warranty, patent infringement, and limitation of liability.

TI warrants performance of its products to the specifications applicable at the time of sale in accordance with TI's standard warranty. Testing and other quality control techniques are utilized to the extent TI deems necessary to support this warranty. Specific testing of all parameters of each device is not necessarily performed, except those mandated by government requirements.

Customers are responsible for their applications using TI components.

In order to minimize risks associated with the customer's applications, adequate design and operating safeguards must be provided by the customer to minimize inherent or procedural hazards.

TI assumes no liability for applications assistance or customer product design. TI does not warrant or represent that any license, either express or implied, is granted under any patent right, copyright, mask work right, or other intellectual property right of TI covering or relating to any combination, machine, or process in which such products or services might be or are used. TI's publication of information regarding any third party's products or services does not constitute TI's approval, license, warranty or endorsement thereof.

Reproduction of information in TI data books or data sheets is permissible only if reproduction is without alteration and is accompanied by all associated warranties, conditions, limitations and notices. Representation or reproduction of this information with alteration voids all warranties provided for an associated TI product or service, is an unfair and deceptive business practice, and TI is not responsible nor liable for any such use.

Resale of TI's products or services with statements different from or beyond the parameters stated by TI for that product or service voids all express and any implied warranties for the associated TI product or service, is an unfair and deceptive business practice, and TI is not responsible nor liable for any such use.

Also see: [Standard Terms and Conditions of Sale for Semiconductor Products](http://www.ti.com/sc/docs/stdterms.htm). [www.ti.com/sc/docs/stdterms.htm](http://www.ti.com/sc/docs/stdterms.htm)

### Mailing Address:

Texas Instruments  
Post Office Box 655303  
Dallas, Texas 75265