

EVALUATION KIT
AVAILABLE

MAXIM

Dual, High-Efficiency, Step-Down Converter with Backup Battery Switchover

MAX1774

General Description

The MAX1774 is a complete power-supply solution for PDAs and other hand-held devices. It integrates two high-efficiency step-down converters, a boost converter for backup battery regulation, and four voltage detectors in a small 28-pin QSOP package.

The MAX1774 accepts inputs from +2.7V to +28V and provides an adjustable Main Output from 2.6V to 5.5V at over 2A. The secondary core converter delivers an adjustable voltage from 1V to 5V and can deliver up to 1.5A. Both the main and core regulators have separate shutdown inputs.

When the AC adapter power is removed, an external P-channel MOSFET switches input to the main battery. When the main battery is low, the backup step-up converter sustains the Main Output voltage. When the backup battery can no longer deliver the required load, the system shuts down safely to prevent damage. Four on-board voltage detectors monitor the status of the AC adapter power, main battery, and backup battery.

The MAX1774 evaluation kit is available to help reduce design time.

Applications

Hand-Held Computers
PDAs
Internet Access Tablets
POS Terminals
Subnotebooks

Pin Configuration

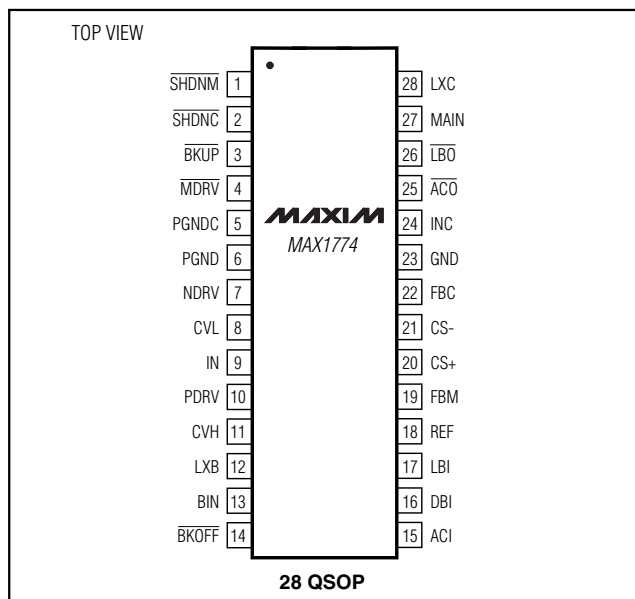

Features

- ◆ Dual, High-Efficiency, Synchronous-Rectified Step-Down Converters
- ◆ Step-Up Converter for Backup Battery
- ◆ Main Power
 - Adjustable from +2.6V to +5.5V
 - Over 2A Load Current
 - Up to 95% Efficiency
- ◆ Core Power
 - Adjustable from 1V to 5V
 - Internal Switches
 - Up to 1.5A Load Current
 - Up to 91% Efficiency
- ◆ Automatic Main Battery Switchover
- ◆ 100% (max) Duty Cycle
- ◆ Up to 1.25MHz Switching Frequency
- ◆ Input Voltage Range from +2.7V to +28V
- ◆ Four Low-Voltage Detectors
- ◆ 170µA Quiescent Current
- ◆ 8µA Shutdown Current
- ◆ Digital Soft-Start
- ◆ Independent Shutdown Inputs

Ordering Information

PART	TEMP. RANGE	PIN-PACKAGE
MAX1774EEI	-40°C to +85°C	28 QSOP

Functional Diagram

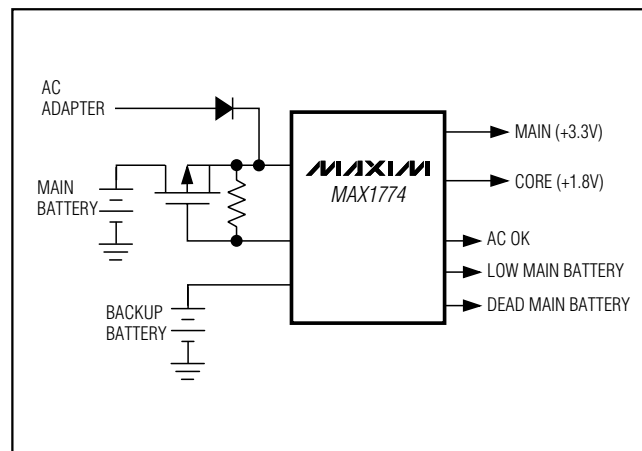

MAXIM

Maxim Integrated Products 1

For price, delivery, and to place orders, please contact Maxim Distribution at 1-888-629-4642, or visit Maxim's website at www.maxim-ic.com.

Dual, High-Efficiency, Step-Down Converter with Backup Battery Switchover

ABSOLUTE MAXIMUM RATINGS

IN, $\overline{\text{SHDNM}}$, $\overline{\text{MDRV}}$, DBI, LBI, ACI,

CVH to GND-0.3V to +30V

IN to CVH, PDRV-0.3V to +6V

BIN to CS--0.3V to +6V

LXB to GND-0.3V to (VBIN + 0.7V)

PDRV to GND(V_{CVH} - 0.3V) to (V_{IN} + 0.3V)

All Other Pins to GND-0.3V to +6V

PGND to GND-0.3V to +0.3V

Continuous Power Dissipation

28-Pin QSOP (derate 10.8mW/°C above +70°C).....860mW

Operating Temperature-40°C to +85°C

Storage Temperature-65°C to +150°C

Lead Temperature (soldering, 10s)+300°C

Stresses beyond those listed under "Absolute Maximum Ratings" may cause permanent damage to the device. These are stress ratings only, and functional operation of the device at these or any other conditions beyond those indicated in the operational sections of the specifications is not implied. Exposure to absolute maximum rating conditions for extended periods may affect device reliability.

ELECTRICAL CHARACTERISTICS

(Figure 1, V_{IN} = +12V, V_{MAIN} = V_{INC} = V_{CS-} = V_{CS+} = +3.3V, V_{CORE} = +1.8V, T_A = 0°C to +85°C, unless otherwise noted. Typical values are at T_A = +25°C.)

PARAMETER	SYMBOL	CONDITIONS	MIN	TYP	MAX	UNITS
Input Voltage	V _{IN}		2.7		28	V
Input Quiescent Supply Current	I _{IN}	V _{FBM} = +1.5V, V _{FBM} = +1.5V, V _{SHDNM} = V _{SHDNC} = +3.3V		18	40	μA
CS- Quiescent Supply Current	I _{CS-}	V _{FBM} = +1.5V, V _{FBM} = +1.5V, V _{SHDNM} = V _{SHDNC} = +3.3V		110	220	μA
Core Regulator Quiescent Supply Current	I _{INC}	V _{FBM} = +1.5V, V _{FBM} = +1.5V, V _{SHDNM} = V _{SHDNC} = +3.3V		60	105	μA
Backup Mode BIN Quiescent Supply Current	I _{BIN}	V _{BIN} = +3.3V, V _{CS-} = +1.5V, V _{FBM} = +1.5V, V _{SHDNM} = +3.3V, V _{BKOFF} = +1.5V, SHDNC = GND		60	105	μA
IN Shutdown Supply Current		$\overline{\text{SHDNM}} = \overline{\text{SHDNC}} = \text{GND}$		8	40	μA
MAIN REGULATOR						
Main Output Voltage Adjust Range			2.6		5.5	V
FBM Regulation Threshold	V _{FBM}	V _(CS+ - CS-) = 0 to +60mV, V _{IN} = +3.5V to +28V	1.21	1.25	1.29	V
FBM Input Current	I _{FBM}	V _{FBM} = +1.3V	-0.1		0.1	μA
Current-Limit Threshold	V _{CCLM}	V _{CS+} - V _{CS-}	60	80	100	mV
Minimum Current-Limit Threshold	V _{MIN}	V _{CS+} - V _{CS-}	5	15	25	mV
Valley Current Threshold	V _{VALLEY}	V _{CS+} - V _{CS-}	40	50	60	mV
Zero Current Threshold	V _{ZERO}	V _{CS+} - V _{CS-}	0	5	15	mV
PDRV, NDRV Gate Drive Resistance		V _{CS-} = +3.3V, I _{LOAD} = 50mA		2	5.5	Ω
CS- to CVL Switch Resistance		I _{CVL} = 50mA		4.5	8	Ω
PDRV, NDRV Dead Time				50		ns

Dual, High-Efficiency, Step-Down Converter with Backup Battery Switchover

MAX1774

ELECTRICAL CHARACTERISTICS (continued)

(Figure 1, $V_{IN} = +12V$, $V_{MAIN} = V_{INC} = V_{CS-} = V_{CS+} = +3.3V$, $V_{CORE} = +1.8V$, $T_A = 0^{\circ}C$ to $+85^{\circ}C$, unless otherwise noted. Typical values are at $T_A = +25^{\circ}C$.)

PARAMETER	SYMBOL	CONDITIONS	MIN	TYP	MAX	UNITS
Maximum Duty Cycle			100			%
Minimum On-Time			200	400	650	ns
Minimum Off-Time			200	400	650	ns
CORE REGULATOR						
Input Voltage Range	V_{INC}		2.6		5.5	V
INC Undervoltage Lockout		V_{INC} rising	2.40	2.47	2.55	V
		V_{INC} falling	2.30	2.37	2.45	
Core Output Voltage Adjust Range			1.0		5.0	V
Maximum Core Load Current		$V_{CORE} = 1.8V$ (Note 1)	1	1.5		A
FBC Regulation Threshold	V_{FBC}	$V_{INC} = +2.5$ to $+5.5V$, $I_{OUTC} = 0$ to $200mA$	0.97	1.0	1.03	V
FBC Input Current	I_{FBC}	$V_{FBC} = +1.3V$	-0.1		0.1	μA
Dropout Voltage		$I_{OUTC} = 400mA$		0.1	0.25	V
LXC Leakage Current	I_{LXC}	$V_{INC} = +5.5V$, $V_{LXC} = 0$ to $+5.5V$	-10		10	μA
LXC P-Channel, N-Channel On-Resistance				0.25	0.5	Ω
LXC P-Channel Current Limit	I_{CLC}		1200	1800	3000	mA
LXC P-Channel Minimum Current			100	250	400	mA
LXC N-Channel Valley Current			900	1400	2400	mA
LXC N-Channel Zero-Crossing Current			40	110	170	mA
LXC Dead Time				50		ns
Max Duty Cycle			100			%
Minimum On-Time			170	400	690	ns
Minimum Off-Time			170	400	690	ns
BACKUP REGULATOR						
Backup Battery Input Voltage	V_{BBATT}		0.9		5.5	V
LXB N-Channel On-Resistance		$V_{CS-} = +3.3V$		1.9	3.5	Ω
LXB Current Limit			200	350	600	mA
LXB Leakage Current	I_{LXB}	$V_{LXB} = +5.5V$, $V_{FBM} = +1.3V$			1	μA
BIN Leakage Current	I_{BIN}	$V_{BIN} = +5.5V$, $CS- = \overline{BKOFF} = SHDNC = SHDNM = GND$			1	μA
BIN, CS- Switch Resistance		$V_{CS-} = +3.3V$, $\overline{BKOFF} = GND$, $SHDNC = SHDNM = CVL$		7.5	15	Ω
BIN Switch Zero-Crossing Threshold		$V_{BIN} = +2.5V$, $\overline{BKOFF} = SHDNC = SHDNM = CVL$		17	35	mV
Maximum Time			2.8	5.6	9.2	μs
Watchdog Timeout				40		μs

Dual, High-Efficiency, Step-Down Converter with Backup Battery Switchover

ELECTRICAL CHARACTERISTICS (continued)

(Figure 1, $V_{IN} = +12V$, $V_{MAIN} = V_{INC} = V_{CS-} = V_{CS+} = +3.3V$, $V_{CORE} = +1.8V$, $T_A = 0^{\circ}C$ to $+85^{\circ}C$, unless otherwise noted. Typical values are at $T_A = +25^{\circ}C$.)

PARAMETER	SYMBOL	CONDITIONS	MIN	TYP	MAX	UNITS
REFERENCE						
Reference Voltage	V_{REF}		1.23	1.25	1.27	V
Reference Load Regulation		$I_{REF} = 0$ to $50\mu A$			10	mV
Reference Line Regulation		$V_{CS-} = +2.5V$ to $+5.5V$, $I_{REF} = 50\mu A$			5	mV
Reference Sink Current	I_{REF}		10			μA
CVL, CVH REGULATORS						
CVL Output Voltage	V_{CVL}	$I_{CVL} = 50mA$, $V_{IN} = +2.7V$, $V_{CS-} = 0$	2.6	2.8	3.1	V
		$I_{CVL} = 50mA$, $V_{CS-} = +3.3V$		3.2		
CVL Switchover Threshold		V_{CS-} rising, hysteresis = 100mV typical	2.40	2.47	2.55	V
CVH Output Voltage	V_{CVH}	$V_{IN} = +4V$, $I_{CVH} = 25mA$		$V_{IN} - 3.4$	$V_{IN} - 2.8$	V
		$V_{IN} = +12V$, $I_{CVH} = 50mA$		$V_{IN} - 4.2$	$V_{IN} - 3.7$	
CVH Switchover Threshold	V_{IN}	V_{IN} rising, hysteresis = 350mV typ		5.5		V
CVL Undervoltage Lockout		V_{CVL} rising	2.40	2.47	2.55	V
		V_{CVL} falling	2.30	2.37	2.45	
LOW-VOLTAGE COMPARATORS						
Backup Regulator Shutdown Threshold	V_{BKOFF}	V_{BKOFF} rising	0.51	0.55	0.59	V
		V_{BKOFF} falling	0.46	0.50	0.54	
$BKOFF$ Input Bias Current		$V_{BKOFF} = +5.5V$			1	μA
LBI Threshold	V_{LBI}	V_{LBI} falling, hysteresis = 50mV typical	1.17	1.20	1.23	V
DBI Threshold	V_{DBI}	V_{DBI} falling, hysteresis = 50mV typical	1.17	1.20	1.23	V
$BKUP$ Input Threshold			0.4			V
LBI, DBI Input Leakage Current		$V_{LBI} = V_{DBI} = +1.3V$			100	nA
LBO , $BKUP$, ACO , $MDRV$ Output Low		$I_{SINK} = 1mA$			0.4	V
LBO , $BKUP$, ACO , $MDRV$ Output Leakage Current		$V_{LBI} = +1.3V$, $V_{ACI} = +12V$, $V_{ACO} = V_{LBO} = V_{BKUP} = +5.5V$, $V_{MDRV} = +28V$			1.0	μA
ACI Threshold		$V_{ACI} - V_{MAIN}$		0.22	0.5	V
ACI Input Leakage Current		$V_{ACI} = +1.3V$			100	nA
Main Input Leakage Current		$V_{MAIN} = +3.3V$		1.5	10	μA
LOGIC INPUTS						
\overline{SHDNM} , \overline{SHDNC} Input Low Voltage					0.4	V
\overline{SHDNM} , \overline{SHDNC} Input High Voltage			2.0			V

Dual, High-Efficiency, Step-Down Converter with Backup Battery Switchover

MAX1774

ELECTRICAL CHARACTERISTICS (continued)

(Figure 1, $V_{IN} = +12V$, $V_{MAIN} = V_{INC} = V_{CS-} = V_{CS+} = +3.3V$, $V_{CORE} = +1.8V$, $T_A = 0^{\circ}C$ to $+85^{\circ}C$, unless otherwise noted. Typical values are at $T_A = +25^{\circ}C$.)

PARAMETER	SYMBOL	CONDITIONS	MIN	TYP	MAX	UNITS
\overline{SHDNM} , \overline{SHDNC} Input Low Current		$\overline{SHDNM} = \overline{SHDNC} = GND$	-1		1	μA
\overline{SHDNC} Input High Current		$V_{\overline{SHDNC}} = +5.5V$			5	μA
\overline{SHDNM} Input High Current		$V_{\overline{SHDNM}} = +5V$		2	25	μA

ELECTRICAL CHARACTERISTICS

(Figure 1, $V_{IN} = +12V$, V_{INC} , $V_{CS} = +3.3V$, $V_{CORE} = +1.8V$, $T_A = -40^{\circ}C$ to $+85^{\circ}C$, unless otherwise noted.) (Note 2)

PARAMETER	SYMBOL	CONDITIONS	MIN	MAX	UNITS
Input Voltage	V_{IN}		2.7	28	V
Input Quiescent Supply Current	I_{IN}	$V_{FBM} = +1.5V$, $V_{FBC} = +1.5V$, $V_{\overline{SHDNM}} = V_{\overline{SHDNC}} = +3.3V$		40	μA
CS- Quiescent Supply Current	I_{CS-}	$V_{FBM} = +1.5V$, $V_{FBC} = +1.5V$, $V_{\overline{SHDNM}} = V_{\overline{SHDNC}} = +3.3V$		220	μA
Core Regulator Quiescent Supply Current	I_{INC}	$V_{FBM} = +1.5V$, $V_{FBC} = +1.5V$, $V_{\overline{SHDNM}} = V_{\overline{SHDNC}} = +3.3V$		105	μA
Backup Mode BIN Quiescent Supply Current	I_{BIN}	$V_{BIN} = +3.3V$, $V_{CS-} = +1.5V$, $V_{FBM} = +1.5V$, $V_{\overline{SHDNM}} = +3.3V$, $V_{BKOFF} = +1.5V$, $\overline{SHDNC} = GND$		110	μA
IN Shutdown Supply Current		$\overline{SHDNM} = \overline{SHDNC} = GND$		40	μA
MAIN REGULATOR					
Main Output Voltage Adjust Range			2.6	5.5	V
FBM Regulation Threshold	V_{FBM}	$V_{(CS+ - CS-)} = 0$ to $+60mV$, $V_{IN} = +3.5V$ to $+28V$	1.21	1.29	V
FBM Input Current	I_{FBM}	$V_{FBM} = +1.3V$	-0.1	0.1	μA
Current-Limit Threshold	V_{CLM}	$V_{CS+} - V_{CS-}$	60	100	mV
Minimum Current-Limit Threshold	V_{MIN}	$V_{CS+} - V_{CS-}$	5	25	mV
Valley Current Threshold	V_{VALLEY}	$V_{CS+} - V_{CS-}$	40	60	mV
Zero Current Threshold	V_{ZERO}	$V_{CS+} - V_{CS-}$	0	15	mV
PDRV, NDRV Gate Drive Resistance		$V_{CS-} = +3.3V$, $I_{LOAD} = 50mA$		5.5	Ω
CS- to CVL Switch Resistance		$I_{CVL} = 50mA$		8	Ω
Maximum Duty Cycle			100		%
Minimum On-Time			200	650	ns
Minimum Off-Time			200	650	ns

Dual, High-Efficiency, Step-Down Converter with Backup Battery Switchover

ELECTRICAL CHARACTERISTICS (continued)

(Figure 1, $V_{IN} = +12V$, V_{INC} , $V_{CS} = +3.3V$, $V_{CORE} = +1.8V$, $T_A = -40^{\circ}C$ to $+85^{\circ}C$, unless otherwise noted.) (Note 2)

PARAMETER	SYMBOL	CONDITIONS	MIN	MAX	UNITS
CORE REGULATOR					
Input Voltage Range	V_{INC}		2.6	5.5	V
INC Undervoltage Lockout		V_{INC} rising	2.39	2.55	V
		V_{INC} falling	2.29	2.45	
Core Output Voltage Adjust Range			1.0	5.0	V
Maximum Core Load Current		$V_{CORE} = 1.8V$ (Note 1)	1		A
FBC Regulation Threshold	V_{FBC}	$V_{INC} = +2.5$ to $+5.5V$, $I_{OUTC} = 0$ to $200mA$	0.97	1.03	V
FBC Input Current	I_{FBC}	$V_{FBC} = +1.3V$	-0.1	0.1	μA
Dropout Voltage		$I_{OUTC} = 400mA$		0.25	V
LXC Leakage Current	I_{LXC}	$V_{INC} = +5.5V$, $V_{LXC} = 0$ to $+5.5V$	-10	10	μA
LXC P-Channel, N-Channel On-Resistance				0.5	Ω
LXC P-Channel Current Limit			1200	3010	mA
LXC P-Channel Minimum Current			100	420	mA
LXC N-Channel Valley Current			880	2450	mA
LXC N-Channel Zero-Crossing Current			40	170	mA
Max Duty Cycle			100		%
Minimum On-Time			170	690	ns
Minimum Off-Time			170	690	ns
BACKUP REGULATOR					
Backup Battery Input Voltage	V_{BBATT}		0.9	5.5	V
LXB N-Channel On Resistance		$V_{CS-} = +3.3V$		2	Ω
LXB Current Limit			200	600	mA
LXB Leakage Current	I_{LXB}	$V_{LXB} = +5.5V$, $V_{FBM} = +1.3V$		1	μA
BIN Leakage Current	I_{BIN}	$V_{BIN} = +5.5V$, $CS- = \overline{BKOFF} = \overline{SHDNC} = \overline{SHDNM} = GND$		1	μA
BIN, CS- Switch Resistance		$V_{CS-} = +3.3V$, $\overline{BKOFF} = GND$, $\overline{SHDNC} = CVL$		15	Ω
BIN Switch Zero-Crossing Threshold		$V_{BIN} = +2.5V$, $\overline{BKOFF} = \overline{SHDNC} = \overline{SHDNM} = CVL$		35	mV
Maximum Time			2.8	9.2	μs
REFERENCE					
Reference Voltage	V_{REF}		1.220	1.275	V
Reference Load Regulation		$I_{REF} = 0$ to $50\mu A$		10	mV
Reference Line Regulation		$V_{CS-} = +2.5V$ to $+5.5V$, $I_{REF} = 50\mu A$		5	mV
Reference Sink Current	I_{REF}		10		μA

Dual, High-Efficiency, Step-Down Converter with Backup Battery Switchover

MAX1774

ELECTRICAL CHARACTERISTICS (continued)

(Figure 1, $V_{IN} = +12V$, V_{INC} , $V_{CS} = +3.3V$, $V_{CORE} = +1.8V$, $T_A = -40^{\circ}C$ to $+85^{\circ}C$, unless otherwise noted.) (Note 2)

PARAMETER	SYMBOL	CONDITIONS	MIN	MAX	UNITS
CVL, CVH REGULATORS					
CVL Output Voltage	V_{CVL}	$I_{CVL} = 50mA$, $V_{IN} = +2.7V$, $V_{CS} = 0$	2.6	3.1	V
CVL Switchover Threshold		V_{CS} - rising, hysteresis = 100mV typical	2.40	2.55	V
CVH Output Voltage	V_{CVH}	$V_{IN} = +4V$, $I_{CVH} = 25mA$		$V_{IN} - 2.8$	V
		$V_{IN} = +12V$, $I_{CVH} = 50mA$		$V_{IN} - 3.65$	
CVL Undervoltage Lockout		V_{CVL} rising	2.40	2.57	V
		V_{CVL} falling	2.30	2.47	
LOW-VOLTAGE COMPARATORS					
Backup Regulator Shutdown Threshold	V_{BKOFF}	V_{BKOFF} rising	0.51	0.59	V
		V_{BKOFF} falling	0.46	0.54	
BKOFF Input Bias Current		$V_{BKOFF} = +5.5V$		1	μA
LBI Threshold	V_{LBI}	V_{LBI} falling, hysteresis = 50mV typical	1.17	1.23	V
DBI Threshold	V_{DBI}	V_{DBI} falling, hysteresis = 50mV typical	1.17	1.23	V
BKUP Input Threshold			0.4		V
LBI, DBI Input Leakage Current		V_{LBI} , $V_{DBI} = +28V$		100	nA
LBO, BKUP, ACO, MDRV Output Low		$I_{SINK} = 1mA$		0.4	V
LBO, BKUP, ACO, MDRV Output Leakage Current		$V_{LBI} = +1.3V$, $V_{ACI} = V_{IN} = +12V$, $V_{ACO} = V_{LBO} = V_{BKUP} = +5.5V$, $V_{MDRV} = +28V$		1.0	μA
ACI Threshold		$V_{ACI} - V_{MAIN}$, ACI falling		0.5	V
ACI Input Leakage Current		$V_{ACI} = +1.3V$		100	nA
MAIN Input Leakage Current		$V_{MAIN} = +3.3V$		10	μA
LOGIC INPUTS					
SHDNM, SHDNC Input Low Voltage				0.4	V
SHDNM, SHDNC Input High Voltage			2.0		V
SHDNM, SHDNC Input Low Current		$\overline{SHDNM} = \overline{SHDNC} = GND$	-1	1	μA
SHDNC Input High Current		$V_{SHDNC} = +5.5V$		5	μA
SHDNM Input High Current		$V_{SHDNM} = +28V$		25	μA

Note 1: This parameter is guaranteed based on the LXC P-channel current limit and the LXC N-channel valley current.

Note 2: Specifications to $-40^{\circ}C$ are guaranteed by design and not production tested.

Dual, High-Efficiency, Step-Down Converter with Backup Battery Switchover

Typical Operating Characteristics

(Circuit of Figure 1, $V_{IN} = +5V$, $V_{INC} = +3.3V$, $T_A = +25^\circ C$, unless otherwise noted.)

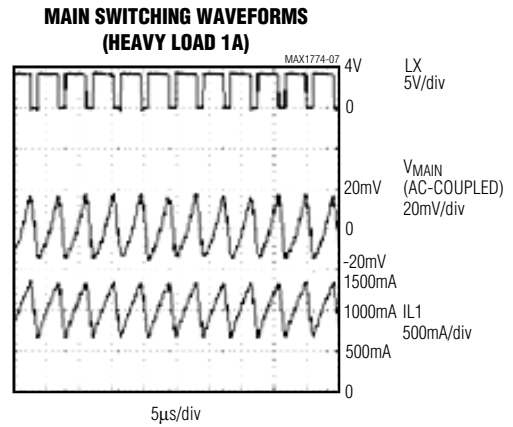
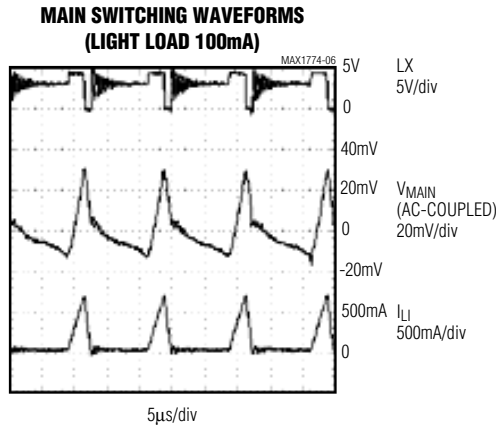
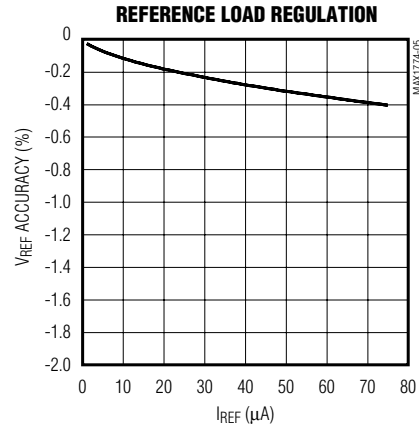
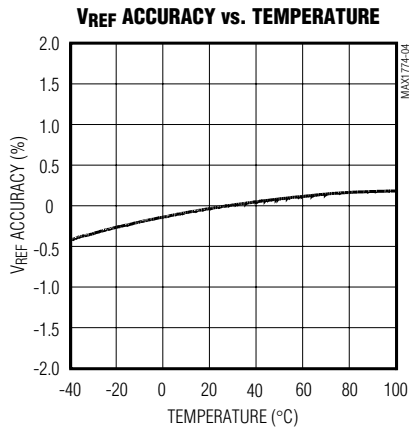
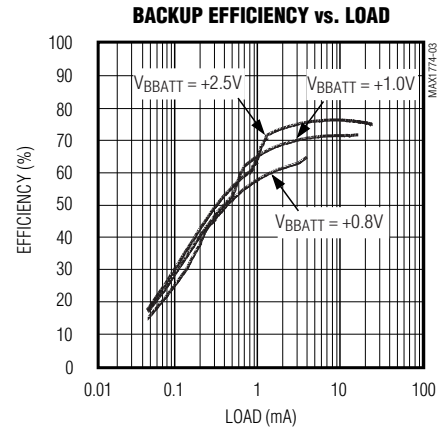
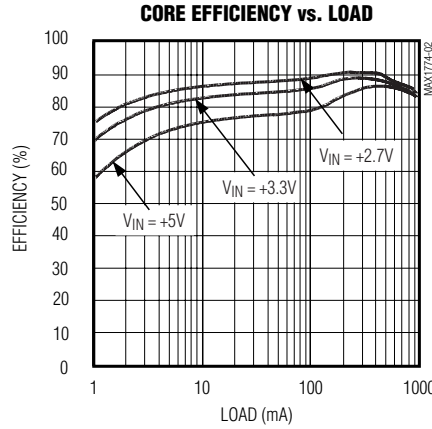
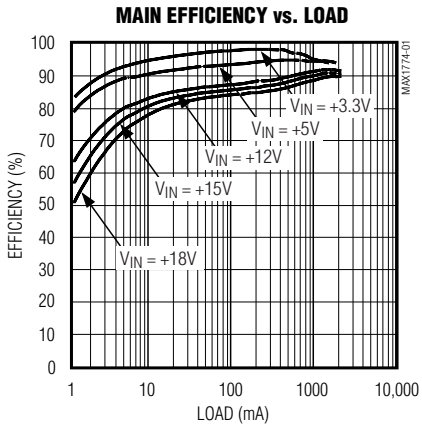

Dual, High-Efficiency, Step-Down Converter with Backup Battery Switchover

MAX1774

Typical Operating Characteristics (continued)

(Circuit of Figure 1, $V_{IN} = +5V$, $V_{INC} = +3.3V$, $T_A = +25^\circ C$, unless otherwise noted.)

**CORE SWITCHING WAVEFORMS
(LIGHT LOAD 50mA)**

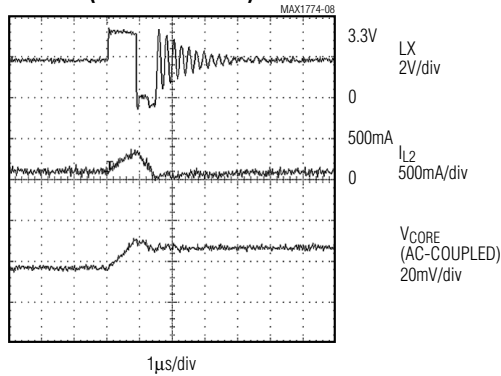

**CORE SWITCHING WAVEFORMS
(HEAVY LOAD 500mA)**

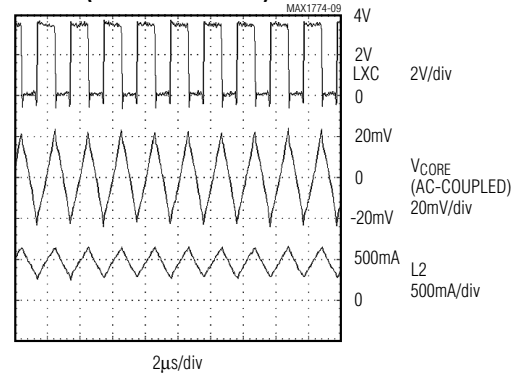

MAIN LINE-TRANSIENT RESPONSE

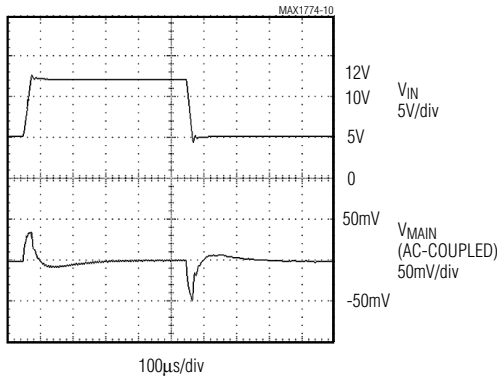

CORE LINE-TRANSIENT RESPONSE

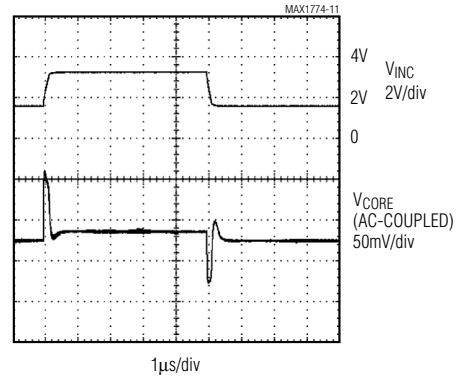

MAIN LOAD-TRANSIENT RESPONSE

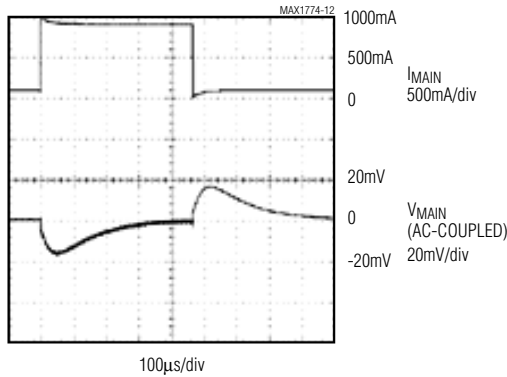

**MAIN LOAD-TRANSIENT RESPONSE
50mA TO 500mA**

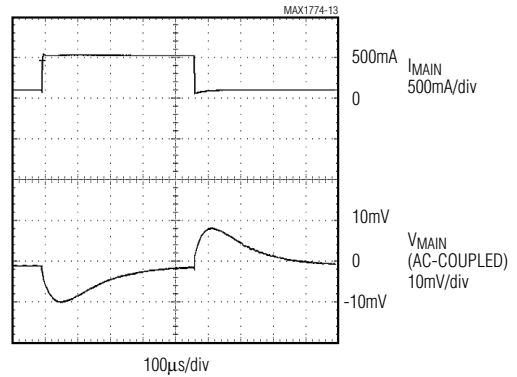

Dual, High-Efficiency, Step-Down Converter with Backup Battery Switchover

Typical Operating Characteristics (continued)

(Circuit of Figure 1, $V_{IN} = +5V$, $V_{INC} = +3.3V$, $T_A = +25^\circ C$, unless otherwise noted.)

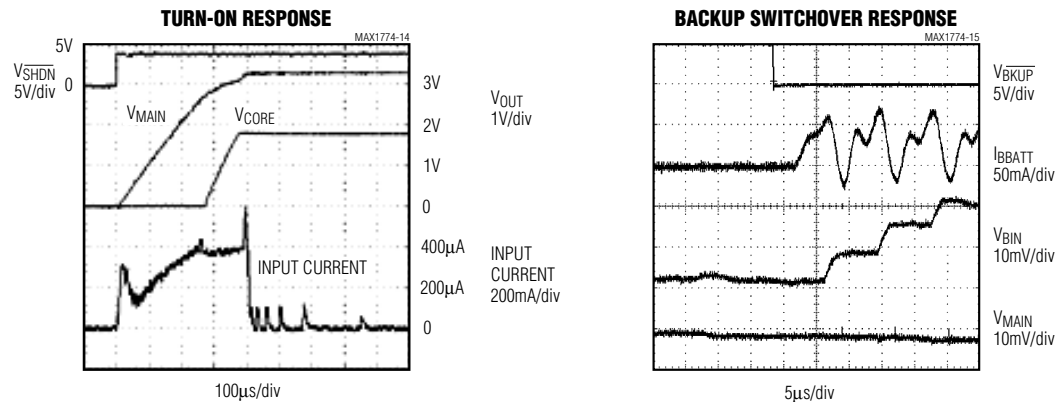

Pin Description

PIN	NAME	FUNCTION
1	\overline{SHDNM}	Shutdown for Main Regulator. Low voltage on \overline{SHDNM} shuts off the main output. For normal operation, connect \overline{SHDNM} to IN.
2	\overline{SHDNC}	Shutdown for Core Regulator. Low voltage on \overline{SHDNC} shuts off the core output. For normal operation, connect \overline{SHDNC} to CVL.
3	\overline{BKUP}	Open-Drain Backup Input/Output. The device is in backup mode when \overline{BKUP} is low. \overline{BKUP} can be externally pulled low to place the device in backup mode.
4	\overline{MDRV}	Open-Drain Drive Output. \overline{MDRV} goes low when the ACI voltage drops below the main voltage plus 220mV and device is not in backup. Connect \overline{MDRV} to the gate of the main battery P-channel MOSFET to switch the battery to IN when the AC adapter voltage is not present.
5	PGND	Power Ground for the Core Converter. Connect all grounds together close to the IC.
6	PGND	Power Ground. Ground for NDRV and core output synchronous rectifier. Connect all grounds together close to the IC.
7	NDRV	N-Channel Drive Output. Drives the main output synchronous-rectifier MOSFET. NDRV swings between CVL and PGND.
8	CVL	Low-Side Bypass. CVL is the output of an internal LDO regulator. This is the internal power supply for the device control circuitry as well as the N-channel driver. Bypass CVL with a 1.0µF or greater capacitor to GND. When CS- is above the CVL switchover threshold (2.47V), CVL is powered from the main output.
9	IN	Power Supply Input
10	PDRV	P-Channel Drive Output. Drives the main output high-side MOSFET switch. PDRV swings between IN and CVH. The voltage at CVH is regulated at $V_{IN} - 4.2V$ unless the input voltage is less than 5.5V.
11	CVH	High-Side Drive Bypass. This is the low-side of the P-channel driver output. Bypass with a 1.0µF capacitor or greater to IN. When the input voltage is less than 5.5V, CVH is switched to PGND.
12	LXB	Backup Converter Switching Node. Connect an inductor from LXB to the backup battery and a Schottky diode to BIN to complete the backup converter. In backup mode, this step-up converter powers the main output from the backup battery through BIN.

Dual, High-Efficiency, Step-Down Converter with Backup Battery Switchover

Pin Description (continued)

MAX1774

PIN	NAME	FUNCTION
13	BIN	Backup Battery Input. Connect BIN to the output of the backup boost regulator. Bypass BIN with a 10 μ F or greater capacitor to GND. When the MAX1774 is in backup mode, BIN powers the main output.
14	$\overline{\text{BKOFF}}$	Backup Disable Input. Driving $\overline{\text{BKOFF}}$ below +0.5V disables the backup mode. In backup mode, the device enters shutdown when this pin is pulled low. $\overline{\text{BKOFF}}$ can be driven from a digital signal or can be used as a low battery detector to disable the backup converter when the backup battery is low.
15	ACI	AC Adapter Low-Voltage Detect Input. Connect to adapter DC input. When the voltage at ACI falls below the main output voltage plus +0.22V, $\overline{\text{ACO}}$ asserts.
16	DBI	Dead Battery Input. Connect DBI to the main battery through a resistive voltage-divider. When DBI drops below +1.20V, no AC adapter is connected ($\overline{\text{ACO}}$ is low, but main output still available), $\overline{\text{BKUP}}$ asserts.
17	LBI	Low-Battery Input. Connect LBI to the main battery through a resistive voltage-divider. When the voltage at LBI drops below +1.20V, $\overline{\text{LBO}}$ asserts.
18	REF	Reference Voltage Output. Bypass REF to GND with a 0.22 μ F or greater capacitor.
19	FBM	Main Output Feedback. Connect FBM to a resistive voltage-divider to set main output voltage between +2.6V to +5.5V.
20	CS+	Main Regulator High-Side Current-Sense Input. Connect the sense resistor between CS+ and CS-. This voltage is used to set the current limit and to turn off the synchronous rectifier when the inductor current approaches zero.
21	CS-	Main Regulator Low-Side Current-Sense Input. Connect CS- to the main output.
22	FBC	Core Output Feedback. Connect FBC to a resistive voltage-divider to set core output between +1.0V to +5.0V.
23	GND	Analog Ground
24	INC	Core Supply Input
25	$\overline{\text{ACO}}$	Low AC Output. Open drain $\overline{\text{ACO}}$ asserts when ACI falls below the main output voltage plus 0.22V.
26	$\overline{\text{LBO}}$	Open-Drain Low-Battery Output. $\overline{\text{LBO}}$ asserts when LBI falls below +1.20V.
27	MAIN	Main Voltage Sense Input. Connect MAIN to the main output.
28	LXC	Core Converter Switching Node

Detailed Description

The MAX1774 dual step-down DC-DC converter is designed to power PDA, palmtop, and subnotebook computers. Normally, these devices require two separate power supplies—one for the processor and another higher voltage supply for the peripheral circuitry. The MAX1774 provides an adjustable +2.6V to +5.5V main output designed to power the peripheral circuitry of PDAs and similar devices. The main output delivers up to 2A output current. The lower voltage core converter has an adjustable +1.0V to +5.0V output, providing up to 1.5A output current. Both regulators utilize a proprietary regulation scheme allowing PWM operation at medium to heavy loads, and automatically switch to pulse skipping at light loads for improved efficiency.

Under low-battery conditions, the MAX1774 enters backup mode, making use of a low-voltage backup battery and a step-up regulator to power the output. Figure 1 is the MAX1774 typical application circuit.

Operating Modes for the Step-Down Converters

When delivering low output currents, the MAX1774 operates in discontinuous conduction mode. Current through the inductor starts at zero, rises as high as the minimum current limit (I_{MIN}), then ramps down to zero during each cycle (see *Typical Operating Characteristics*). The switch waveform may exhibit ringing, which occurs at the resonant frequency of the inductor and stray capacitance, due to the residual energy trapped in the core

Dual, High-Efficiency, Step-Down Converter with Backup Battery Switchover

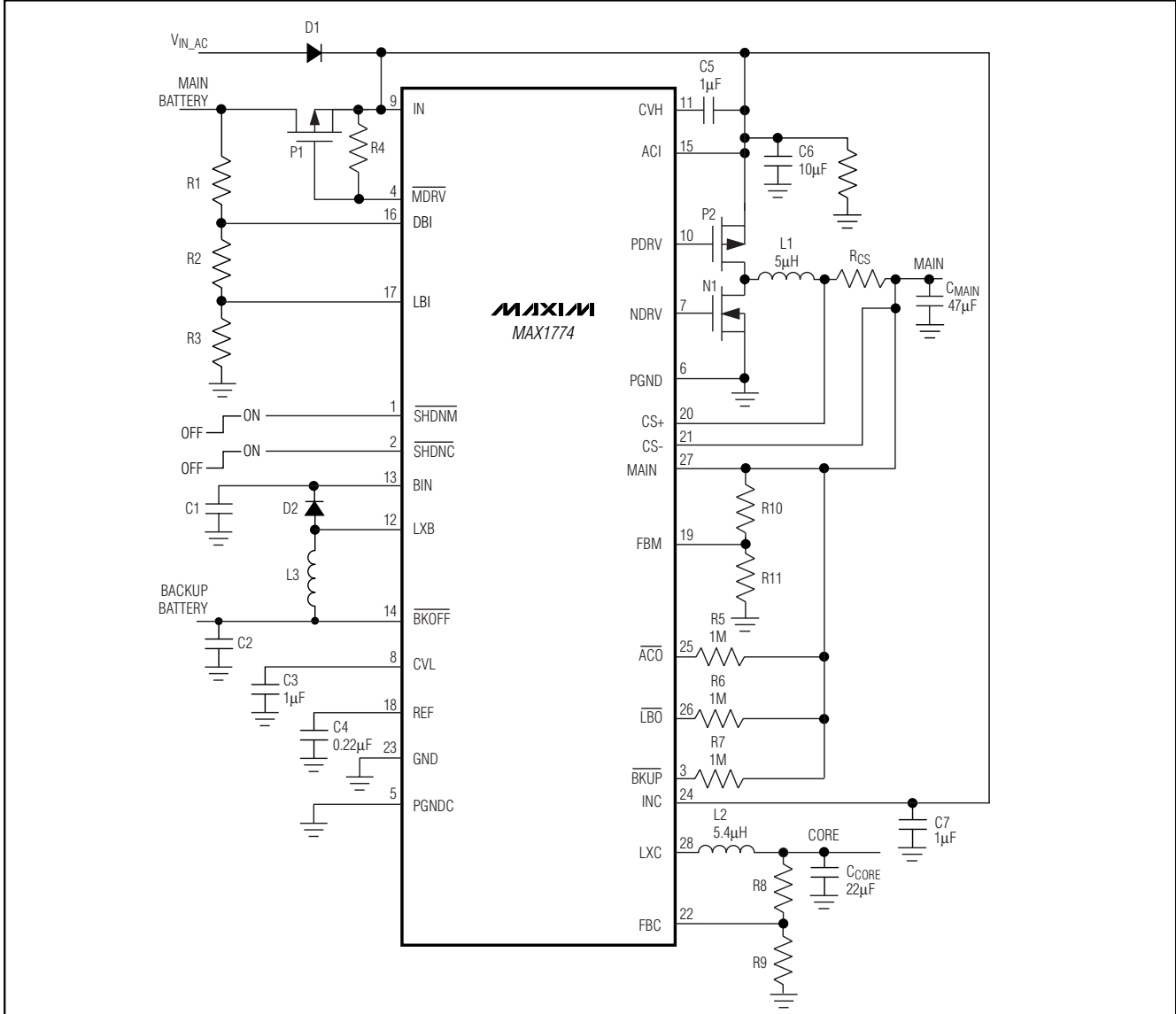

Figure 1. Typical Application Circuit

when the rectifier MOSFET turns off. This ringing is normal and does not degrade circuit performance.

When delivering medium-to-high output currents, the MAX1774 operates in PWM continuous-conduction mode. In this mode, current always flows through the inductor and never ramps to zero. The control circuit adjusts the switch duty cycle to maintain regulation without exceeding the peak switching current set by the current-sense resistor.

100% Duty Cycle and Dropout

The MAX1774 operates with a duty cycle up to 100%, extending the input voltage range by turning the MOSFET on continuously when the supply voltage approaches the output voltage. This services the load when conventional switching regulators with less than 100% duty cycle fail. Dropout voltage is defined as the difference between the input and output voltages when the input is low enough for the output to drop out of regulation. Dropout depends on the MOSFET drain-to-

Dual, High-Efficiency, Step-Down Converter with Backup Battery Switchover

MAX1774

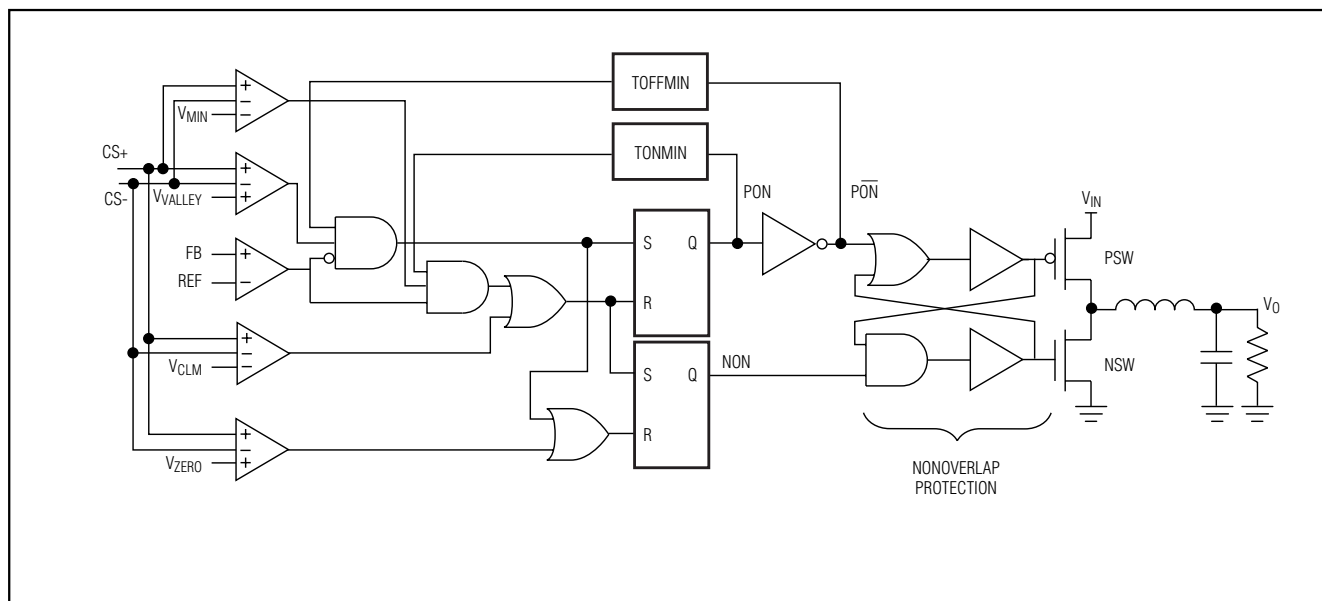

Figure 2. Simplified Control System Block Diagram

source on-resistance, current-sense resistor, and inductor series resistance, and is proportional to the load current:

$$V_{DROPOUT} = I_{OUT} [R_{DS(ON)} + R_{SENSE} + R_L]$$

Regulation Control Scheme

The MAX1774 has a unique operating scheme that allows PWM operation at medium and high current, automatically switching to pulse-skipping mode at lower currents to improve light-load efficiency. Figure 2 shows a simplified block diagram.

Under medium and heavy load operation, the inductor current is continuous and the part operates in PWM mode. In this mode, depending on the duty cycle, either the minimum on-time or the minimum off-time sets the switching frequency. The duty cycle is approximately the output voltage divided by the input voltage. If the duty cycle is less than 50%, the minimum on-time controls the frequency, and the frequency is approximately $f \approx 2.5\text{MHz} \times D$, where D is the duty cycle. If the duty cycle is greater than 50%, the minimum off-time sets the frequency, and the frequency is approximately $f \approx 2.5\text{MHz} \times (1 - D)$.

In both cases, the error comparator regulates the voltage. For low duty cycles (<50%), the P-channel MOSFET is turned on for the minimum on-time, causing fixed-on-time operation. During the MOSFET on-time, the output voltage rises. Once the MOSFET is turned

off, the voltage drops to the regulation threshold, when another cycle is initiated. For high duty cycles (>50%), the MOSFET remains off for the minimum off-time, causing fixed-off-time operation. In this case, the MOSFET remains on until the output voltage rises to the regulation threshold. Then the MOSFET turns off for the minimum off-time, initiating another cycle.

By switching between fixed-on-time and fixed-off-time operation, the MAX1774 can operate at high input-output ratios and still operate up to 100% duty cycle for low dropout. When operating from fixed-on-time operation, the minimum output voltage is regulated, but in fixed-off-time operation, the maximum output voltage is regulated. Thus, as the input voltage drops below approximately twice the output voltage, a decrease in line regulation can be expected. The drop in voltage is approximately $V_{DROP} \approx V_{RIPPLE}$. At light output loads, the inductor current is discontinuous, causing the MAX1774 to operate at lower frequencies, reducing the MOSFET gate drive and switching losses. In discontinuous mode, under most circumstances, the on-time will be a fixed minimum on-time of 400ns.

The MAX1774 features four separate current-limit threshold detectors and a watchdog timer for each of its step-down converters. In addition to the more common peak current detector and zero-crossing detector, each converter also provides a valley current detector (IVALLEY), and a minimum current detector (IMIN).

Dual, High-Efficiency, Step-Down Converter with Backup Battery Switchover

IVALLEY is used to force the inductor current to drop to a lower level after hitting peak current before allowing the P-channel MOSFET to turn on. This is a safeguard against inductor current significantly overshooting above the peak current when the inductor discharges too slowly when V_{OUT}/L is small. I_{MIN} is useful in ensuring that a minimum current is built up in the inductor before turning off the P-channel MOSFET. This helps the inductor to charge the output near dropout when the di/dt is small (because $(V_{IN} - V_{OUT}) / L$ is small) to avoid multiple pulses and low efficiency. This feature, however, is disabled during dropout and light-load conditions where the inductor current may take too long to reach the I_{MIN} value. A watchdog timer overrides I_{MIN} after the P-channel MOSFET has been on for longer than about 10 μ s.

Main Step-Down Converter

The main step-down converter features adjustable +2.6V to +5.5V output delivering up to 2A from a +2.7V to +28V input (see *Setting the Output Voltages*). The use of external MOSFETs and current-sense resistor maximizes design flexibility. The MAX1774 offers a synchronous-rectifier MOSFET driver that improves efficiency by eliminating losses through a diode. The two MOSFET drive outputs, PDRV and NDRV, control these external MOSFETs. The output swing of these outputs is limited to reduce power consumption by limiting the amount of injected gate charge (see *Internal Linear Regulators* section for details). Current-limit detection for all main converter current limits is sensed through a small-sense resistor at the converters' output (see *Setting the Current Limit* section). Driving the SHDNM pin low puts the main converter in a low-power shutdown mode. The core regulator, low-voltage detectors, and backup converter are still functional when the main converter is in shutdown. When the MAX1774 enters backup mode, the main converter and its current sensor are shut off.

Core Step-Down Converter

The core step-down converter produces a +1.0V to +5.0V output from a +2.6V to +5.5V input. The low-voltage input allows the use of internal power MOSFETs, taking advantage of their low $R_{DS(ON)}$, improving efficiency and reducing board space. Like the main converter, the core regulator makes use of a synchronous-rectifying N-channel MOSFET, improving efficiency and eliminating the need for an external Schottky diode. Current sensing is internal to the device, eliminating the need for an external sense resistor. The maximum and minimum current limits are sensed through the P-channel MOSFET, while the valley current and zero-crossing current are sensed through the N-channel MOSFET.

The core output voltage is measured at FBC through a resistive voltage-divider. This divider can be adjusted to set the output voltage level (see *Setting the Output Voltages*). The core input can be supplied from the main regulator or an external supply that does not exceed +5.5V (see *High-Voltage Configuration and Low-Voltage Configuration* sections). The core converter can be shut down independent of the main converter by driving SHDN \overline{C} low. If the main converter output is supplying power to the core and is shut down, SHDNM controls both outputs. In this configuration, the core converter continues to operate when the MAX1774 is in backup mode.

Voltage Monitors and Battery Switchover

The MAX1774 offers voltage monitors ACI, LBI, DBI, and BKOFF that drive corresponding outputs to indicate low-voltage conditions. The AC adapter low-voltage detect input, ACI, is typically connected to the output of an AC-to-DC converter. When the voltage at ACI drops below the MAIN sense input plus 0.22V, the low AC output, \overline{ACO} , is asserted. Figure 3 shows a simplified block diagram.

The low and dead battery monitors, LBI and DBI, monitor the voltage at MAIN_BATT through a resistive voltage-divider. When the voltage at LBI falls below +1.20V, the low-battery output flag, LBO, is asserted.

When both VIN_AC and MAIN_BATT are present, the MAX1774 chooses one of the two supplies determined by ACI. To facilitate this, the MAX1774 provides an open-drain MOSFET driver output (MDRV). This drives an external P-channel MOSFET used to switch the MAX1774 from the AC input to the battery. MDRV goes low when \overline{ACO} is low, the main battery is not dead, and the MAX1774 is not in backup mode.

The MAX1774 enters backup mode when the voltage at DBI is below +1.20V and VIN_AC is not present to the board. Under these conditions, the BKUP output is asserted (low), and the device utilizes its boost converter and a low-voltage backup battery to supply the main output. The BKUP pin can be driven low externally, forcing the MAX1774 to enter backup mode. If the voltage at BKOFF is less than 0.5V, the backup converter is disabled. BKOFF can be driven from a digital signal, or can be used as a low-battery detector to disable the backup converter when the backup battery is low.

Place 1M Ω pullup resistors from the main output to \overline{ACO} , LBO, and BKUP. Use a 1M Ω pullup resistor from MDRV to IN.

When not in backup mode, the backup regulator is isolated from the main output by an internal switch. When the MAX1774 is in backup mode, the main converter is

Dual, High-Efficiency, Step-Down Converter with Backup Battery Switchover

MAX1774

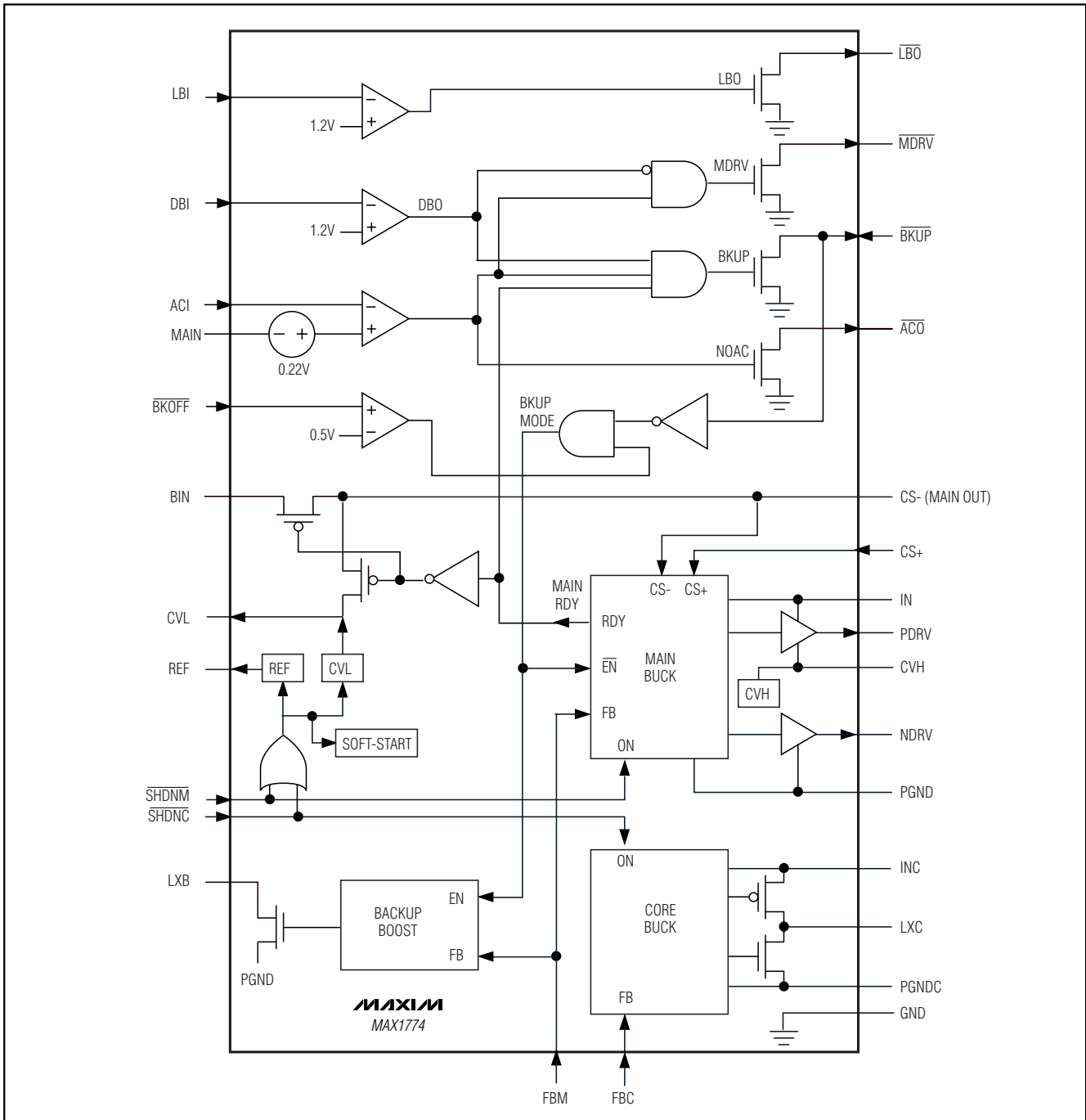

Figure 3. Simplified Block Diagram

Dual, High-Efficiency, Step-Down Converter with Backup Battery Switchover

disabled, and the output of the backup regulator is connected to the main output. The core converter is still operable while in backup mode. The backup step-up converter cannot drive the typical main load current. The load at main must be reduced before entering backup mode.

If $\overline{\text{BKUP}}$ is de-asserted (goes high), the MAX1774 exits backup mode and resumes operation from the main battery or the AC adapter input. If $\overline{\text{BKOFF}}$ goes low, or the backup battery discharges where it cannot sustain the main output load, the backup converter shuts off. To restart the main converter, apply power to $V_{\text{IN_AC}}$ or MAIN_BATT .

The backup converter uses an external Schottky diode and internal power NMOS switch. Since this converter shares the same output as the main buck converter, it shares the same feedback network. This automatically sets the backup converter output voltage to that of the main converter. The backup converter generates an output between +2.6V and +5.5V from a +0.9V to +5.5V input, and provides a load current up to 20mA. When the MAX1774 is in backup mode, the main current-sense circuit is turned off to conserve power.

When the output is out of regulation, the maximum inductor current limit and zero-current detectors regulate switching. The N-channel MOSFET is turned on until the maximum inductor current limit is reached, and shuts off until the inductor current reaches zero. When the output is within regulation, switching is controlled by the maximum pulse width, LXB , switch current limit, zero crossing, and the feedback voltage.

Internal Linear Regulators

There are two internal linear regulators in the MAX1774. A high-voltage linear regulator accepts inputs up to +28V, reducing it to +2.8V at CVL to provide power to the MAX1774. Once the voltage at CS- reaches +2.47V, CVL is switched to CS- , allowing it to be driven from the main converter and improving efficiency. CVL supplies the internal bias to the IC and power for the NDRV gate driver.

The CVH regulator output provides the low-side voltage for the main regulator's PDRV output. The voltage at CVH is regulated at 4.2V below V_{IN} to limit the voltage swing on PDRV , reducing gate charge and improving efficiency (Figure 3).

Reference

The MAX1774 has a trimmed internal +1.25V reference at REF . REF can source no more than 50 μA . Bypass REF to GND with a 0.22 μF capacitor.

Design Procedure

Low-Voltage Configuration

To improve efficiency and conserve board space, the core regulator operates from low input voltages, taking advantage of internal low-voltage, low-on-resistance MOSFETs. When the input voltage remains below 5.5V, run the core converter directly from the input by connecting INC to IN (Figure 1). This configuration takes advantage of the core's low-voltage design and improves efficiency.

High-Voltage Configuration

For input voltages greater than 5.5V, cascade the main and core converters by connecting INC to the main output voltage (Figure 4). In this configuration, the core converter is powered from the main output. Ensure that the main output can simultaneously supply its load and the core input current.

Backup Converter Configuration

The MAX1774 provides a backup step-up converter to power the device and provide the main output voltage when other power fails. The backup converter operates from a +0.9V to +5.5V battery. For most rechargeable batteries, such as NiCd or NiMH, the simple circuit of Figure 5 can be used to recharge the backup battery. In this circuit, the backup battery is charged through R1 and D10 . Consult the battery manufacturer for charging requirements. To prevent the backup battery from overdischarging, connect a resistive voltage-divider from the backup battery to $\overline{\text{BKOFF}}$. Resistor values can be calculated through the following equation:

$$R_{12} = R_{13} \times [(V_{\text{BU}} / V_{\overline{\text{BKOFF}}}) - 1]$$

where $V_{\overline{\text{BKOFF}}} = 0.5\text{V}$, and V_{BU} is the minimum acceptable backup battery voltage. Choose R13 to be less than 150k Ω .

Setting the Output Voltages

The main output voltage must be set from +2.6V and +5.5V with two external resistors connected as a voltage-divider to FBM (Figure 1). Resistor values can be calculated by the following equation:

$$R_{10} = R_{11} \times [(V_{\text{OUTM}} / V_{\text{FBM}}) - 1]$$

where $V_{\text{FBM}} = +1.25\text{V}$. Choose R11 to be 40k Ω or less.

The core regulator output is adjustable from +1.0V to +5.0V through two external resistors connected as a voltage-divider to FBC (Figure 1). Resistor values can be calculated with the following equation:

$$R_8 = R_9 \times [(V_{\text{OUTC}} / V_{\text{FBC}}) - 1]$$

where $V_{\text{FBC}} = +1.0\text{V}$. Choose R9 to be 30k Ω or less.

Dual, High-Efficiency, Step-Down Converter with Backup Battery Switchover

MAX1774

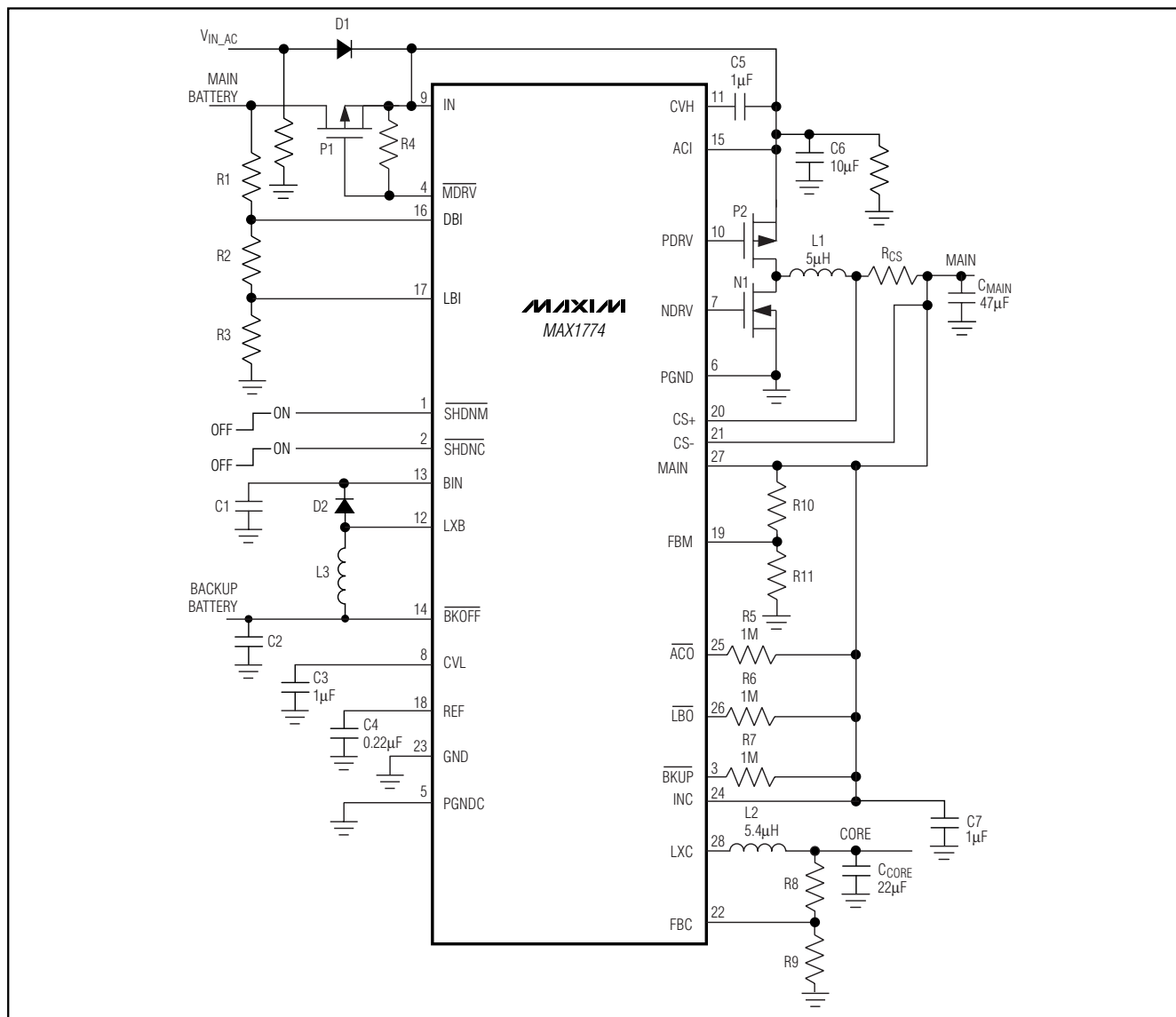

Figure 4. Typical Application Circuit (Cascaded)

Setting the Current Limit

The main regulator current limit is set externally through a small current-sense resistor, R_{CS} (Figure 1). The value of R_{CS} can be calculated with the following equation:

$$R_{CS} = V_{CLM} / (1.3 \times I_{OUT})$$

where $V_{CLM} = 80\text{mV}$ is the current-sense threshold, and I_{OUT} is the current delivered to the output. The core and backup converter current limits are set internally and cannot be modified.

Careful layout of the current-sense signal traces is imperative. Place R_{CS} as close to the MAX1774 as possible. The two traces should have matching length and width, be as far as possible from noisy switching signals, and be close together to improve noise rejection. These traces should be used for current-sense signal routing only and should not carry any load current. Refer to the *MAX1774 evaluation kit* for layout examples.

Dual, High-Efficiency, Step-Down Converter with Backup Battery Switchover

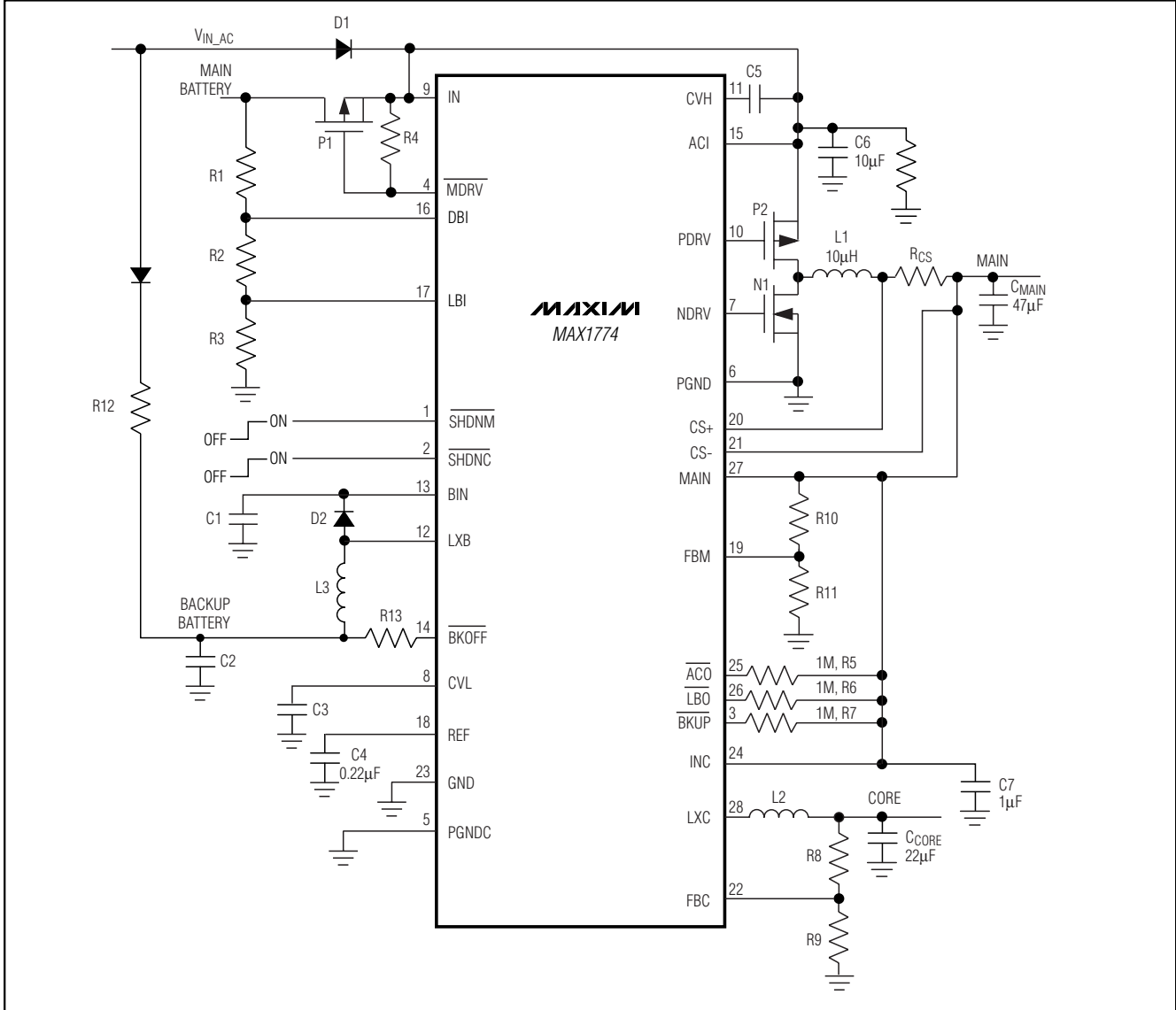

Figure 5. Typical Application Circuit (with Recharge)

Setting the Voltage Monitor Levels

The low battery and dead battery detector trip points can be set by adjusting the resistor values of the divider string (R1, R2, and R3) in Figure 1 according to the following equations:

$$R1 = (R2 + R3) \times [(V_{BD} / V_{TH}) - 1]$$

$$R2 = R3 \times [(V_{BL} / V_{BD}) - 1]$$

where V_{BL} is the low battery voltage, V_{BD} is the dead battery voltage, and $V_{TH} = +1.20V$. Choose R3 to be less than $250k\Omega$.

Inductor Selection

The essential parameters for inductor selection are inductance and current rating. The MAX1774 operates with a wide range of inductance values.

Calculate the inductance value for either CORE or MAIN, L_{MIN} :

Dual, High-Efficiency, Step-Down Converter with Backup Battery Switchover

$$L_{(\text{MIN})} = (V_{\text{IN}} - V_{\text{OUT}}) \times (t_{\text{ON}(\text{MIN})} / I_{\text{RIPPLE}})$$

where $t_{\text{ON}(\text{MIN})}$ is typically 400ns, and I_{RIPPLE} is the continuous conduction peak-to-peak I_{RIPPLE} current.

In continuous conduction, I_{RIPPLE} should be chosen to be 30% of the maximum load current. With high inductor values, the MAX1774 begins continuous-conduction operation at a lower fraction of full load (see *Detailed Description*).

The inductor's saturation current must be greater than the peak switching current to prevent core saturation. Saturation occurs when the inductor's magnetic flux density reaches the maximum level the core can support and inductance starts to fall. The inductor heating current rating must be greater than the maximum load current to prevent overheating. For optimum efficiency, the inductor series resistance should be less than the current-sense resistance.

Capacitor Selection

Choose the output filter capacitors to service input and output ripple current with acceptable voltage ripple. ESR in the output capacitor is a major contributor to output ripple. For the main converter, low-ESR capacitors such as polymer or ceramic capacitors are recommended. For the core converter, choosing a low-ESR tantalum capacitor with enough ESR to generate about 1% ripple voltage across the output is helpful in ensuring stability.

Voltage ripple is the sum of contributions from ESR and the capacitor value:

$$V_{\text{RIPPLE}} \approx V_{\text{RIPPLE,ESR}} + V_{\text{RIPPLE,C}}$$

For tantalum capacitors, the ripple is determined mostly by the ESR. Voltage ripple due to ESR is:

$$V_{\text{RIPPLE,ESR}} \approx (R_{\text{ESR}}) \times I_{\text{RIPPLE}}$$

For ceramic capacitors, the ripple is mostly due to the capacitance. The ripple due to the capacitance is approximately:

$$V_{\text{RIPPLE,C}} \approx L I_{\text{RIPPLE}}^2 C_{\text{OUT}} V_{\text{OUT}}$$

where V_{OUT} is the average output voltage.

These equations are suitable for initial capacitor selection. Final values should be set by testing a prototype or evaluation kit. When using tantalum capacitors, use good soldering practices to prevent excessive heat from damaging the devices and increasing their ESR. Also, ensure that the tantalum capacitors' surge-current ratings exceed the startup inrush and peak switching currents.

The input filter capacitor reduces peak currents drawn from the power source and reduces noise and voltage ripple at I_{N} , caused by the circuit's switching. Use a

low-ESR capacitor. Two smaller value low-ESR capacitors can be connected in parallel if necessary. Choose input capacitors with working voltage ratings higher than the maximum input voltage.

MOSFET Selection

The MAX1774 drives an external enhancement-mode P-channel MOSFET and a synchronous-rectifier N-channel MOSFET. When selecting the MOSFETs, important parameters to consider are on-resistance ($R_{\text{DS(ON)}}$), maximum drain-to-source voltage ($V_{\text{DS(MAX)}}$), maximum gate-to-source voltage ($V_{\text{GS(MAX)}}$), and minimum threshold voltage ($V_{\text{TH(MIN)}}$).

Chip Information

TRANSISTOR COUNT: 4545

PROCESS: BiCMOS

Dual, High-Efficiency, Step-Down Converter with Backup Battery Switchover

Package Information

QSOP-EPS

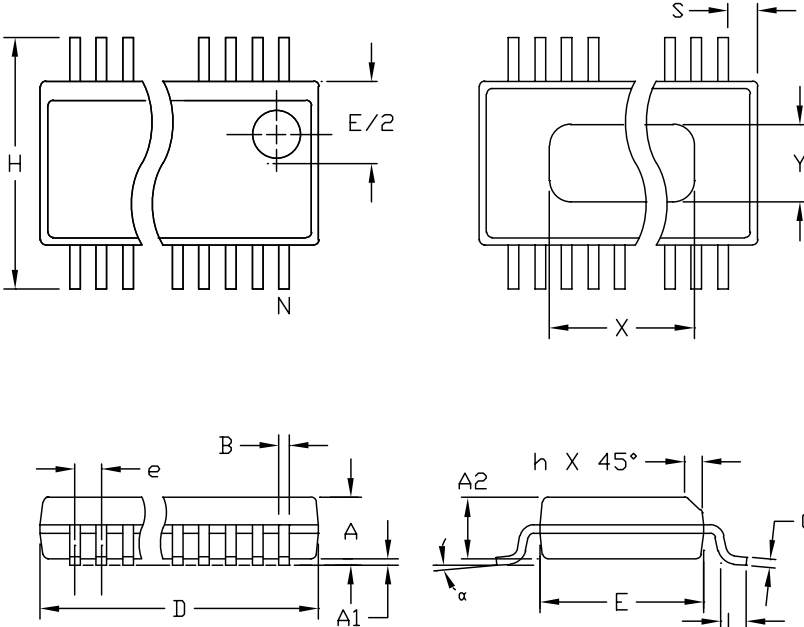

DIM	INCHES		MILLIMETERS	
	MIN	MAX	MIN	MAX
A	.061	.068	1.55	1.73
A1	.004	.0098	0.102	0.249
A2	.055	.061	1.40	1.55
B	.008	.012	0.20	0.31
C	.0075	.0098	0.191	0.249
D	SEE VARIATIONS			
E	.150	.157	3.81	3.99
e	.025 BSC		0.635 BSC	
H	.230	.244	5.84	6.20
h	.010	.016	0.25	0.41
L	.016	.035	0.41	0.89
N	SEE VARIATIONS			
X	SEE VARIATIONS			
Y	.071	.087	1.803	2.209
α	0°	8°	0°	8°

VARIATIONS:

DIM	INCHES		MILLIMETERS		N
	MIN.	MAX.	MIN.	MAX.	
D	.189	.196	4.80	4.98	16 AA
S	.0020	.0070	0.05	0.18	
X	.107	.123	2.72	3.12	
D	.337	.344	8.56	8.74	20 AB
S	.0500	.0550	1.270	1.397	
D	.337	.344	8.56	8.74	24 AC
S	.0250	.0300	0.635	0.762	
D	.386	.393	9.80	9.98	28 AD
S	.0250	.0300	0.635	0.762	
X	.271	.287	6.88	7.29	

NOTES:

1. D & E DO NOT INCLUDE MOLD FLASH OR PROTRUSIONS
2. MOLD FLASH OR PROTRUSIONS NOT TO EXCEED .006" PER SIDE.
3. HEAT SLUG DIMENSIONS X AND Y APPLY ONLY TO 16 AND 28 LEAD POWER-QSOP PACKAGES.
4. CONTROLLING DIMENSIONS: INCHES.

MAXIM
 PROPRIETARY INFORMATION
 TITLE:
 PACKAGE OUTLINE, QSOP, .150", .025" LEAD PITCH
 APPROVAL: _____ DOCUMENT CONTROL NO. 21-0055 REV B 1/1

Note: The MAX1774 does not have a heat slug.

Maxim cannot assume responsibility for use of any circuitry other than circuitry entirely embodied in a Maxim product. No circuit patent licenses are implied. Maxim reserves the right to change the circuitry and specifications without notice at any time.

20 _____ Maxim Integrated Products, 120 San Gabriel Drive, Sunnyvale, CA 94086 408-737-7600